

2		1						
		REVISIONS						
ZONE	LTR.	DESCRIPTION	DATE	ECN	BY	CKD	APVD	
-	B	REDRAWN FOR LABELING CONSISTENCY	01/02/16	2016-76	TB	AB	AA	

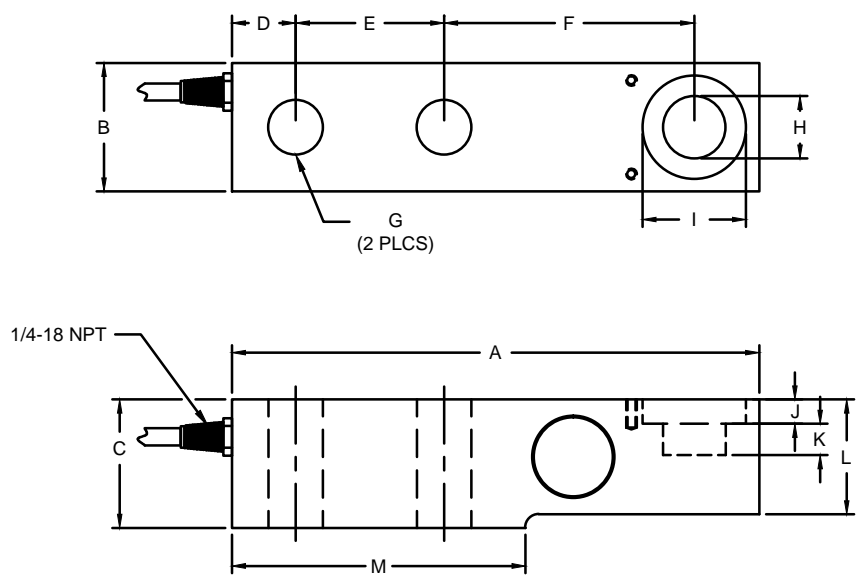

- PERFORMANCE SPECIFICATIONS:**
1. CAPACITIES: 45K. (LB)
 2. RATED OUTPUT: 2.00 mV/V $\pm 0.25\%$.
 3. SAFE OVERLOAD: 150% FS.
 4. EXCITATION VOLTAGE: 10V AC/DC (15V MAX).
 5. INPUT RESISTANCE: 380 $\pm 10\Omega$.
 6. OUTPUT RESISTANCE: 350 $\pm 3\Omega$.
 7. ZERO BALANCE: $\pm 1.00\%$ FS.
 8. SEAL TYPE: ENVIRONMENTALLY-SEAL IP67.
 9. NON-LINEARITY: $\pm 0.03\%$ FS.
 10. HYSTERESIS: $\pm 0.03\%$ FS.
 11. REPEATABILITY: $\pm 0.01\%$ FS.
 12. CREEP: $\pm 0.02\%$ FS IN 30 MINUTES.
 13. COMPENSATED TEMPERATURE RANGE: -10°C TO $+40^{\circ}\text{C}$.
 14. TEMPERATURE EFFECT ON ZERO: $\pm 0.0027\%$ FS/ $^{\circ}\text{C}$.
 15. TEMPERATURE EFFECT ON OUTPUT: $\pm 0.0015\%$ FS/ $^{\circ}\text{C}$.
 16. INSULATION RESISTANCE: 5000 MEGOHMS.
 17. LOAD CELL CABLE: 4-22AWG, $\varnothing 6.8\text{MM}$, BRAIDED, 50FT.
 18. LOAD CELL WIRING:
 - GRN (+EXC)
 - BLK (-EXC)
 - WHT (+SIG)
 - RED (-SIG)
 - BRAID/YELLOW: SHIELD
 19. FM APPROVED.

RATED CAPACITY	DIMENSIONS												
	A	B	C	D	E	F	G	H	I	J	K	L	M
45K	12.50	2.75	3.25	1.25	3.50	6.25	1.31	1.50	2.00	0.38	0.56	2.76	6.22

DO NOT ALTER WITHOUT AGENCY NOTIFICATION

COTI GLOBAL SENSORS, INC.

**CG - SB2L
LOAD CELL**

<p>THIS DRAWING USES THIRD ANGLE PROJECTION</p> <p>THIS DOCUMENT CONTAINS PROPRIETARY INFORMATION AND SUCH INFORMATION MAY NOT BE REPRODUCED OR DISCLOSED FOR ANY PURPOSE OR USED TO PRODUCE THE ARTICLE OR SUBJECT WITHOUT WRITTEN PERMISSION FROM COTI GLOBAL SENSORS, INC.</p>	<p>TOLERANCES UNLESS OTHERWISE SPECIFIED</p> <p>.XX = $\pm 0.02"$</p> <p>.XXX = $\pm 0.005"$</p> <p>.XXXX = $\pm 0.0002"$</p> <p>FRACTIONS: $\pm 1/16"$</p> <p>ANGLES: DEG. $\pm 1/8$</p>	APPROVALS		DATE	<table border="1"> <tr> <td>SCALE</td> <td>SIZE</td> <td>PART/DRAWING NO.</td> <td>REV.</td> </tr> <tr> <td>NONE</td> <td>B</td> <td>DOD-CG-SB2L</td> <td>B</td> </tr> </table>	SCALE	SIZE	PART/DRAWING NO.	REV.	NONE	B	DOD-CG-SB2L	B
		SCALE	SIZE	PART/DRAWING NO.		REV.							
		NONE	B	DOD-CG-SB2L		B							
		DRAWN:	RLU	06/16/15									
		CHECKED:	AA	06/16/15									
ENGINEER:	JSP	06/16/15											
APPROVED:	AA	06/16/15											
MATERIAL:	ALLOY STEEL		MODEL	CG-SB2L	SHEET	1 OF 1							
FINISH:	NICKEL PLATED												