

HRP 4Y.KO Mass Comparator

Class-leading manual mass comparator

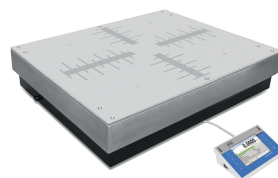

HRP 200.4Y.KO



HRP 2000.1.4Y.KO

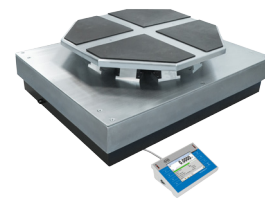

HRP 2000.1.4Y.KO with self-centring weighing pan



Precisely marked weighing platform

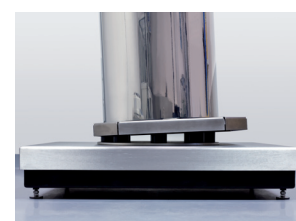

Comparison of weights loaded off-centre

Functions

- 

Mass comparator
- 

Ambient conditions measurement
- 

Proximity sensors
- 

Replaceable units
- 

Multilingual menu

Features

Effective and Excellent Measurement

The HRP 4Y.KO mass comparator represents the professional-class manual mass comparators. The comparator allows to compare weights of class F2 and lower of mass ranging between 50 kg and 1000 kg.

Design and Functionality

Precisely marked weighing platform of the HRP 4Y.KO mass comparator enables centring loading of weights. The device is equipped with self-centring weighing pan to provide comfort of the operation and reduce eccentricity error. The self-centring weighing pan ensures stabilization and levelling of the weights loaded off-centre and to compare weights of different shapes.

Dedicated Software







Specially designed RMCS computer software enables comprehensive realisation of calibration procedures in laboratory. The system manages the whole calibration process, starting from the moment the order is placed, through procedure performance, to the moment of issuing the calibration certificate.

Technical Specifications

	HRP 200.4Y.KO	HRP 500.4Y.KO	HRP 500.1.4Y.KO
OIML calibration range E1	—	—	—
OIML calibration range E2	—	—	—
OIML calibration range F1	—	—	500 kg
OIML calibration range F2	100 kg ÷ 200 kg	200 kg ÷ 500 kg	100 kg ÷ 500 kg
OIML calibration range M1	50 kg ÷ 200 kg	100 kg ÷ 500 kg	20 kg ÷ 500 kg
OIML calibration range M2	50 kg ÷ 200 kg	50 kg ÷ 500 kg	10 kg ÷ 500 kg
Maximum capacity [Max]	210 kg	510 g	510 g
Readability [d]	0.2 g	0.5 g	0,1 g
Repeatability absolute *	1 g (200 kg)	3 g (500 kg)	0.7 g (500 kg)
Repeatability nominal load *	0.6 g (200 kg)	1.6 g (500 kg)	0.4 g (500 kg)
Repeatability low load *	0.4 g (20 kg)	0.6 g (50 kg)	0.2 g (50 kg)
Repeatability typical *	0.5 g (200 kg)	1 g (500 kg)	0.3 g (500 kg)
Stabilization time	10 s	10 s	15 s
Adjustment	external	external	external
Electric compensation range	0 g ÷ 210 kg	0 g ÷ 510 kg	0 g ÷ 510 kg
Eccentricity (for test weight)	2 d / 1 mm	2 d / 1 mm	2 d / 1 mm
Maximum permissible weight loading speed	0.6 m / min	0.6 m / min	0.6 m / min
Recommended weight loading speed	0.3 m / min	0.3 m / min	0.3 m / min
Display	5.7" colour resistive touch screen	5.7" colour resistive touch screen	5.7" colour resistive touch screen
Keypad	8 keys	8 keys	8 keys
Ingress protection - indicator	IP 43	IP 43	IP 43
Touch-free operation	2 programmable sensors	2 programmable sensors	2 programmable sensors
USB-A	2	2	2
Ethernet	10 / 100 Mbit	10 / 100 Mbit	10 / 100 Mbit
RS 232	2	2	2
Wi-Fi®	802.11 b/g/n	802.11 b/g/n	802.11 b/g/n
IN/OUT	4 × IN, 4 × OUT	4 × IN, 4 × OUT	4 × IN, 4 × OUT
Power supply	110 ÷ 230 V AC / 50 ÷ 60 Hz	110 ÷ 230 V AC / 50 ÷ 60 Hz	110 ÷ 230 V AC / 50 ÷ 60 Hz
Operating temperature	+15 ÷ +30 °C	+15 ÷ +30 °C	+15 ÷ +30 °C
Operating temperature change rate	± 1 °C / 12 h	± 1 °C / 12 h	± 1 °C / 12 h
Relative humidity variations	±5% / 4 h	±5% / 4 h	±5% / 4 h
Relative humidity***	40 ÷ 60%	40 ÷ 60%	40 ÷ 60%
Transport and storage temperature	-20 ÷ +50 °C	-20 ÷ +50 °C	-20 ÷ +50 °C
Weighing pan dimensions	800 × 600 mm	800 × 600 mm	800 × 600 mm
Self-centring weighing pan dimensions**	600 × 600 mm	600 × 600 mm	600 × 600 mm
Mass comparator dimensions	809 × 600 × 162 mm	809 × 600 × 162 mm	809 × 600 × 162 mm
Dimensions of mass comparator with self-centring weighing pan**	809 × 600 × 255 mm	809 × 600 × 255 mm	809 × 600 × 255 mm
Indicator dimensions	206 × 140 × 70 mm	206 × 140 × 70 mm	206 × 140 × 70 mm
Mass comparator net weight	73.5 kg	73.5 kg	73.5 kg
Mass comparator gross weight	96.5 kg	96.5 kg	96.5 kg
Net weight of mass comparator with self-centring weighing pan**	142.5 kg	142.5 kg	142.5 kg
Gross weight of mass comparator with self-centring weighing pan**	170 kg	170 kg	170 kg
Mass comparator packaging dimensions	1000 × 800 × 307 mm	1000 × 800 × 307 mm	1000 × 800 × 307 mm
Packaging dimensions of mass comparator with self-centring weighing pan**	1000 × 800 × 357 mm	1000 × 800 × 357 mm	1000 × 800 × 357 mm

* repeatability is expressed as a standard deviation determined for 6 ABBA cycles
 ** optional design
 *** non-condensing conditions

Wi-Fi® is a registered trademark of Wi-Fi Alliance.

		HRP 1000.4Y.KO	HRP 2000.4Y.KO	HRP 2000.1.4Y.KO
OIML calibration range E1		—	—	—
OIML calibration range E2		—	—	—
OIML calibration range F1		—	—	—
OIML calibration range F2		500 kg ÷ 1000 kg	1000 kg ÷ 2000 kg	—
OIML calibration range M1		200 kg ÷ 1000 kg	500 kg ÷ 2000 kg	500 kg ÷ 2000 kg
OIML calibration range M2		100 kg ÷ 1000 kg	200 kg ÷ 2000 kg	500 kg ÷ 2000 kg
Maximum capacity [Max]		1050 kg	2100 kg	2100 kg
Readability [d]		1 g	2 g	5 g
Repeatability absolute *		5 g (1000 kg)	10 g (2000 kg)	15 g (2000 kg)
Repeatability nominal load *		2.5 g (1000 kg)	5 g (2000 kg)	10 g (2000 kg)
Repeatability low load *		1.5 g (100 kg)	2.5 g (200 kg)	5 g (200 kg)
Repeatability typical *		2 g (1000 kg)	3.5 g (2000 kg)	7 g (2000 kg)
Stabilization time		10 s	10 s	10 s
Adjustment		external	external	external
Electric compensation range		0 g ÷ 1050 kg	0 g ÷ 2100 kg	0 g ÷ 2100 kg
Eccentricity (for test weight)		1 d / 1 mm	1 d / 1 mm	0.5 d / 1 mm
Maximum permissible weight loading speed		0.6 m / min	0.6 m / min	0.6 m / min
Recommended weight loading speed		0.3 m / min	0.3 m / min	0.3 m / min
Display		5.7" colour resistive touch screen	5.7" colour resistive touch screen	5.7" colour resistive touch screen
Keypad		8 keys	8 keys	8 keys
Ingress protection - indicator		IP 43	IP 43	IP 43
Touch-free operation		2 programmable sensors	2 programmable sensors	2 programmable sensors
USB-A		2	2	2
Ethernet		10 / 100 Mbit	10 / 100 Mbit	10 / 100 Mbit
RS 232		2	2	2
Wi-Fi®		802.11 b/g/n	802.11 b/g/n	802.11 b/g/n
IN/OUT		4 × IN, 4 × OUT	4 × IN, 4 × OUT	4 × IN, 4 × OUT
Power supply		110 ÷ 230 V AC / 50 ÷ 60 Hz	110 ÷ 230 V AC / 50 ÷ 60 Hz	110 ÷ 230 V AC / 50 ÷ 60 Hz
Operating temperature		+15 ÷ +30 °C	+15 ÷ +30 °C	+15 ÷ +30 °C
Operating temperature change rate		± 1 °C / 12 h	± 1 °C / 12 h	± 2 °C / 12 h
Relative humidity variations		± 5% / 4 h	± 5% / 4 h	± 10% / 4 h
Relative humidity***		40 ÷ 60%	40 ÷ 60%	40 ÷ 60%
Transport and storage temperature		-20 ÷ +50 °C	-20 ÷ +50 °C	-20 ÷ +50 °C
Weighing pan dimensions		1000 × 800 mm	1250 × 1000 mm	1250 × 1000 mm
Self-centring weighing pan dimensions**		1000 × 800 mm	920 × 920 mm	920 × 920 mm
Mass comparator dimensions		1011 × 800 × 182 mm	1250 × 1000 × 235 mm	1250 × 1000 × 235 mm
Dimensions of mass comparator with self-centring weighing pan**		1011 × 800 × 275 mm	1250 × 1000 × 400 mm	1250 × 1000 × 400 mm
Indicator dimensions		206 × 140 × 70 mm	206 × 140 × 71 mm	206 × 140 × 71 mm
Mass comparator net weight		134 kg	300 kg	300 kg
Mass comparator gross weight		168 kg	400 kg	400 kg
Net weight of mass comparator with self-centring weighing pan**		199 kg	530 kg	530 kg
Gross weight of mass comparator with self-centring weighing pan**		249 kg	665 kg	665 kg
Mass comparator packaging dimensions		1200 × 1000 × 436 mm	1500 × 1250 × 615 mm	1500 × 1250 × 615 mm
Packaging dimensions of mass comparator with self-centring weighing pan**		1200 × 1000 × 481 mm	1500 × 1250 × 713 mm	1500 × 1250 × 713 mm

* repeatability is expressed as a standard deviation determined for 6 ABBA cycles

** optional design

*** non-condensing conditions

Wi-Fi® is a registered trademark of Wi-Fi Alliance.

Dimensions

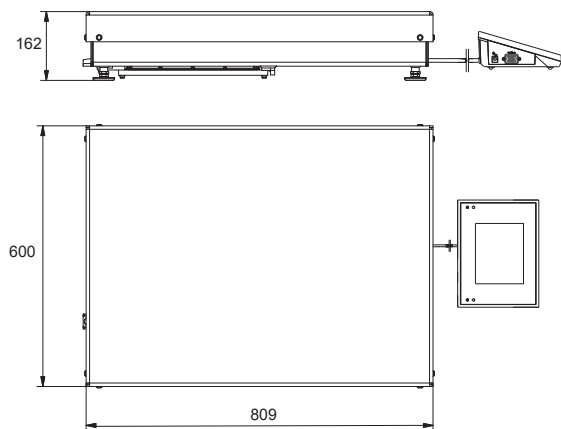

Typ wagi	A1	A2	H
HRP 200.4Y.KO	809	600	162
HRP 500.4Y.KO	809	600	162
HRP 1000.4Y.KO	1011	800	182
HRP 2000.4Y.KO	1250	1000	235
HRP 2000.1.4Y.KO	1250	1000	235

wymiar podawany w mm

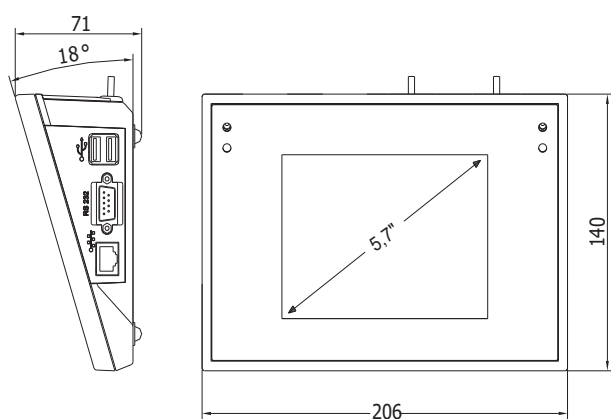

PUE 7.1 indicator

Accessories

Professional Weighing

- self-centring weighing pan

Ambient Conditions

- THB-S or THB-P sensor

Peripheral Devices

- Epson dot matrix printer
- barcode scanner
- WD-5/3Y LCD display (backlit)

Cables, Converters

- RS-232 – P0108 computer cable
- RS-232 – P0167 computer cable
- RS-232 – P0151 Epson printer cable

Electrical Accessories

- power supply with ZR-02 battery

Dedicated Software

RMCS System

- performance of calibration procedures in a laboratory from the moment the order is placed, to the moment of issuing a calibration certificate
- compatible with THB sensors enabling recording ambient conditions
- export of report results to various files
- archiving calibration protocols, orders, certificates and ambient conditions

RADWAG Remote Desktop

- remote control of the mass comparator using computer, telephone or tablet
- sending text messages
- version for Windows 10 and Android systems

R-LAB

- collecting measurements
- carrying out statistical analysis of measurements
- customized graphs and reports

Parameters Editor

- remote change of parameters
- remote on-line preview of the display
- displaying current mass indication
- software update
- file loading, editing and saving parameters to a file
- import and export of parameters
- interfaces: RS232, Ethernet and Wireless Connection
- quick and easy edition of balance parameters using computer